

TYPICAL TYPE "A" LOT

NOT TO SCALE

EXHIBIT "A"

3'-0" x 3'-0" CLEAR
AREA IN FRONT
OF METER PEDESTAL

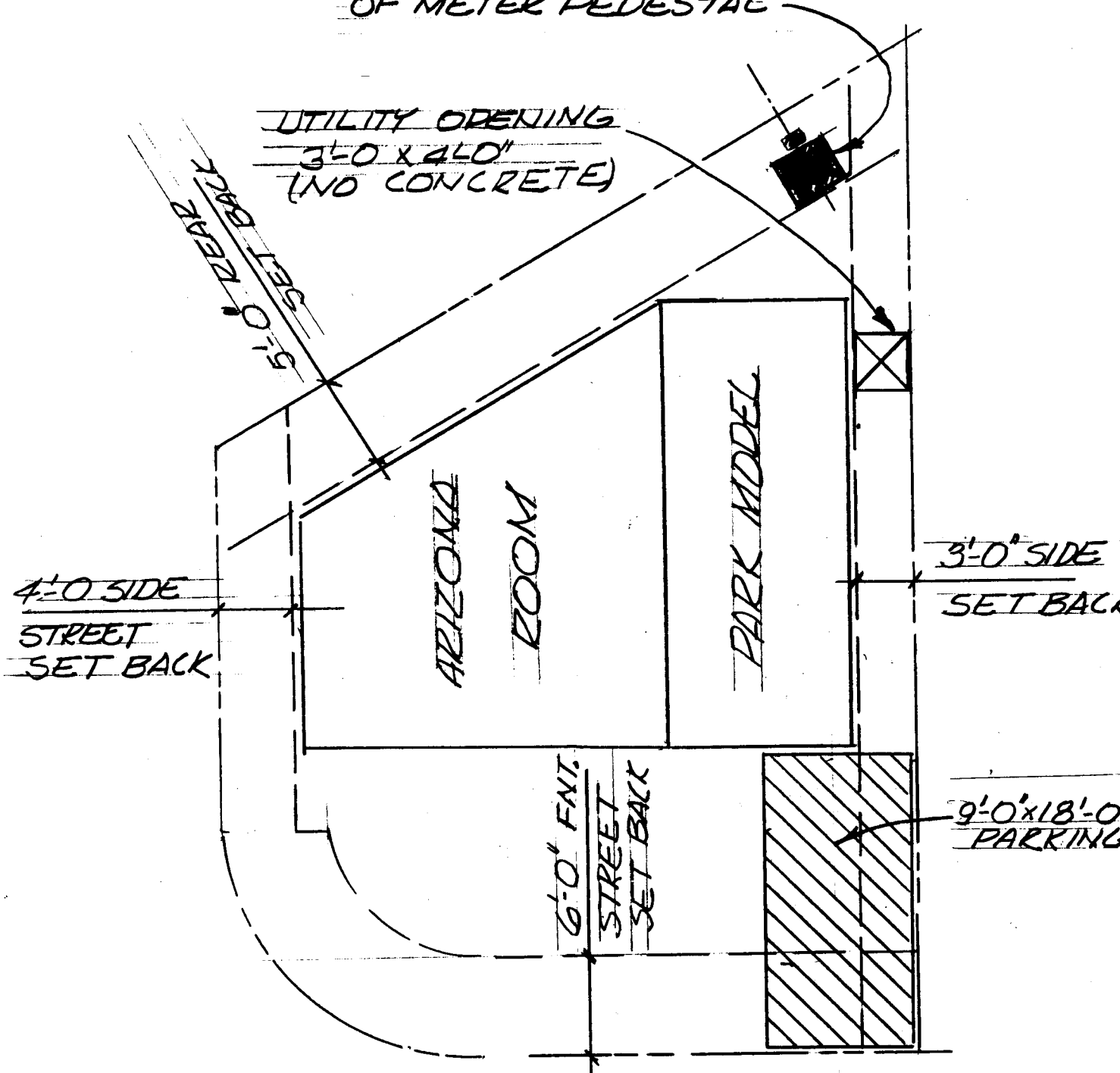

TYPICAL TYPE "B" LOT

NOT TO SCALE

EXHIBIT "B"

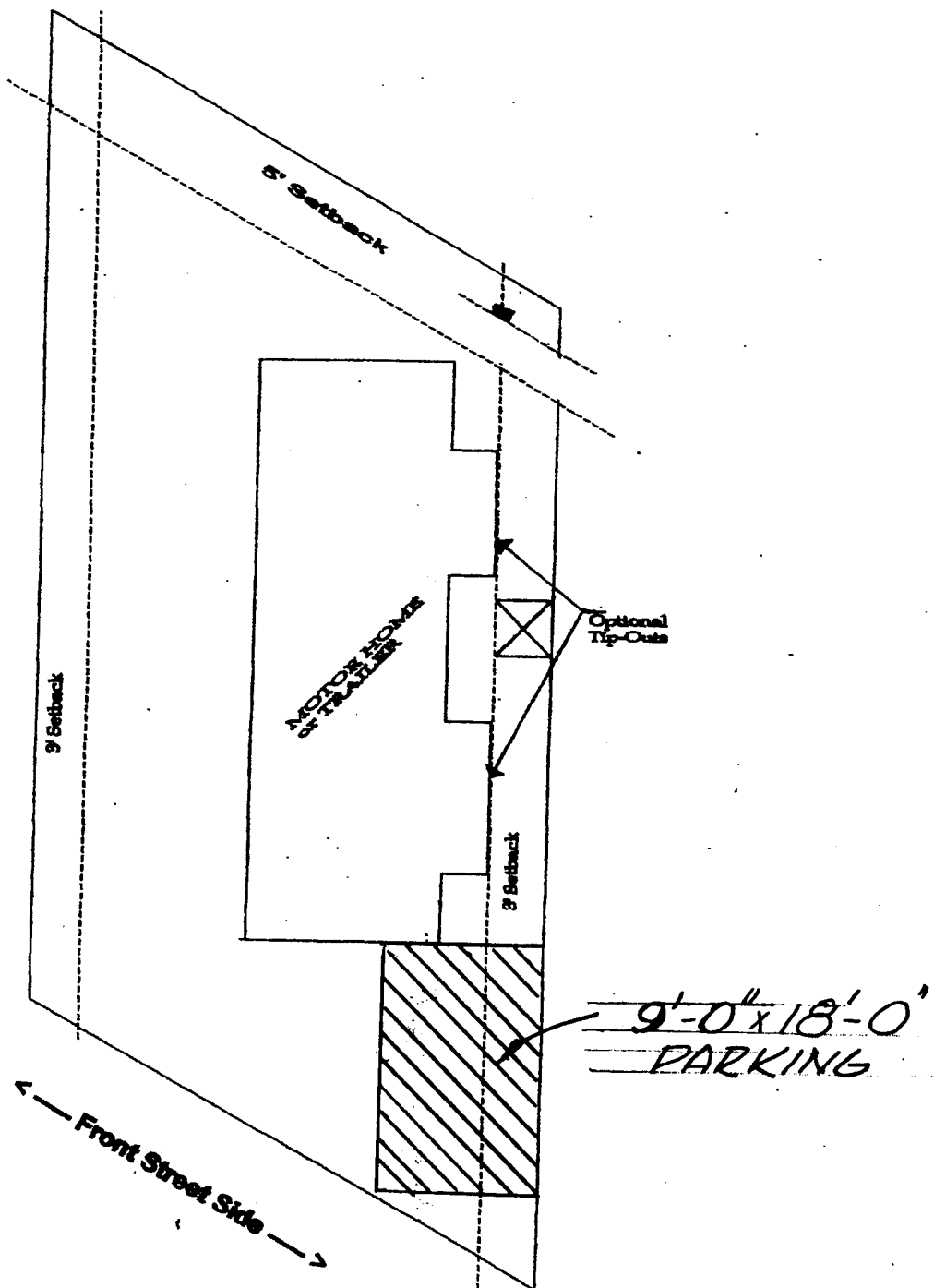

TYPICAL PLACEMENT
 MOTOR HOME, TRAILER OR FIFTH WHEEL

NOT TO SCALE

EXHIBIT "D"

NO ENCROACHMENT
OF SHED OR PARK
MODEL INTO THE
EASEMENT OR
SETBACK AREA

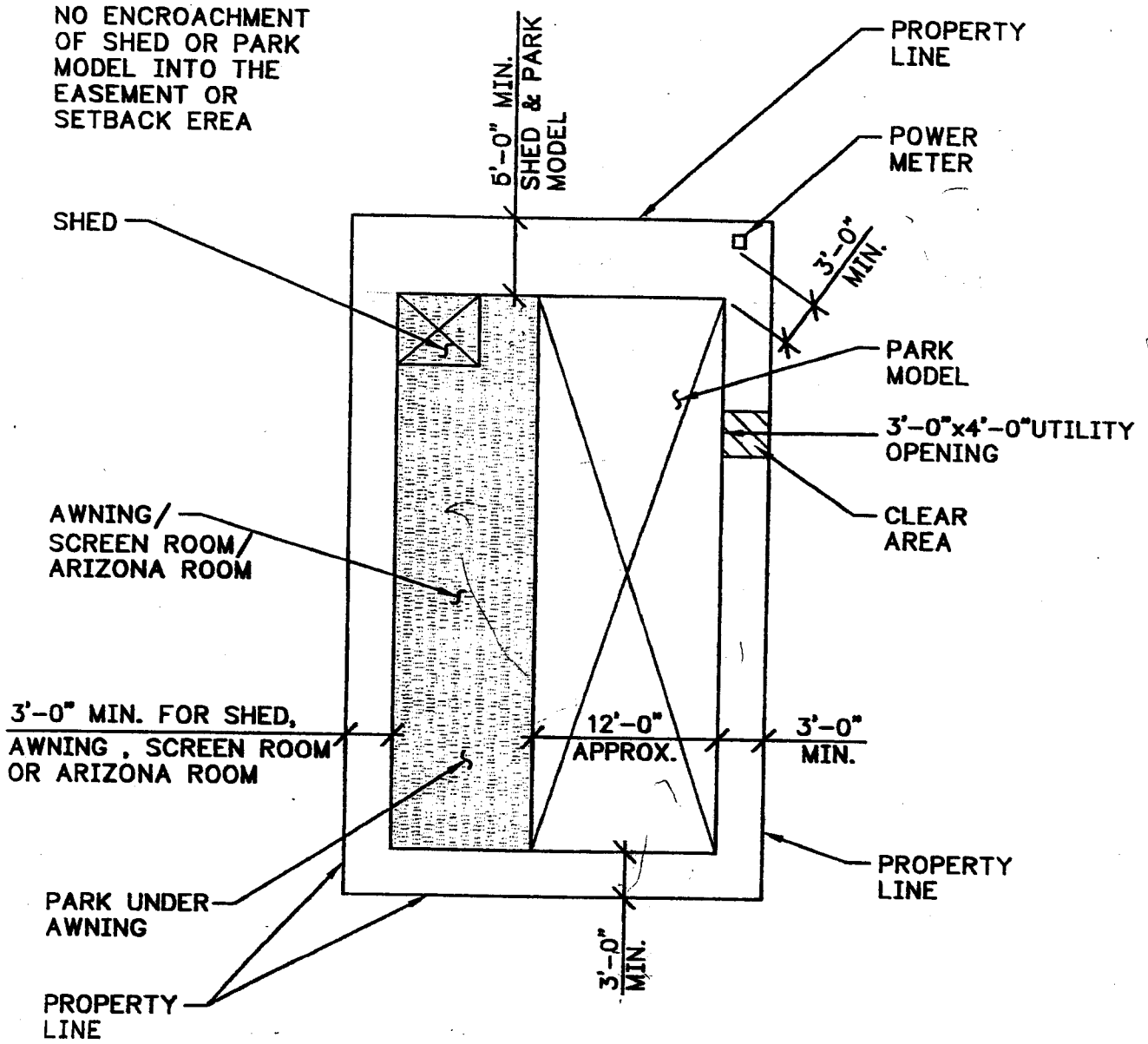

< — Front Street Side — >

TYPICAL TYPE "C" LOT
NOT TO SCALE

EXHIBIT "C"

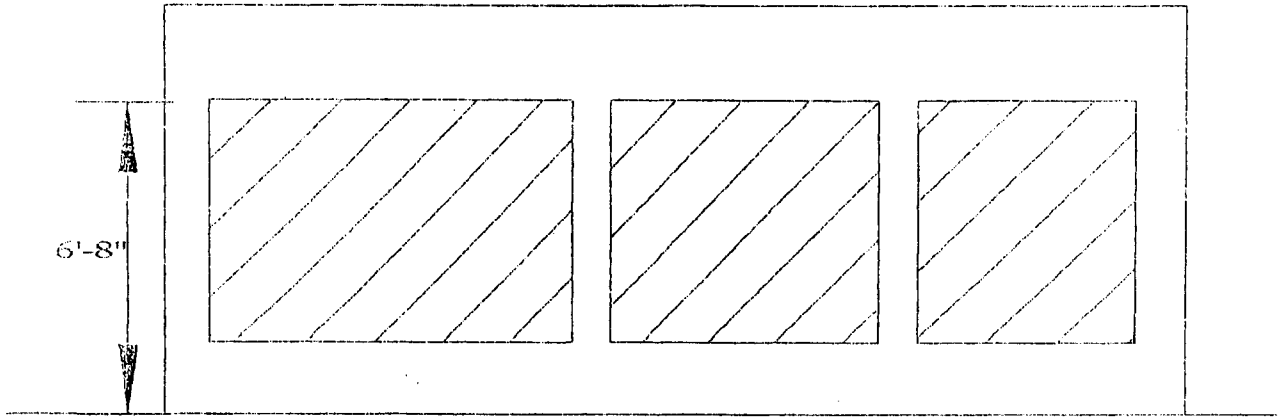

Wall "A" SIDEWALL ILLUSTRATION

NOTE: Screened Area below 6'-8" on the longer wall and one additional wall must be equal to at least 65% of total area of the two walls "A" and "B"

Screen area must be fully removable screen or plexiglass

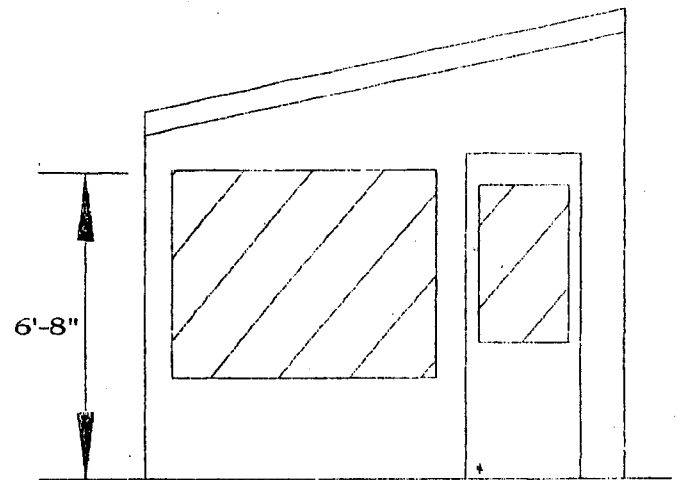

Wall "B" END WALL ILLUSTRATION

CALCULATION: Total area of walls "A" and "B" = xxx sq ft.
 Required screen area = 65% of xxx

TYPICAL SCREEN ROOM

EXHIBIT "F"

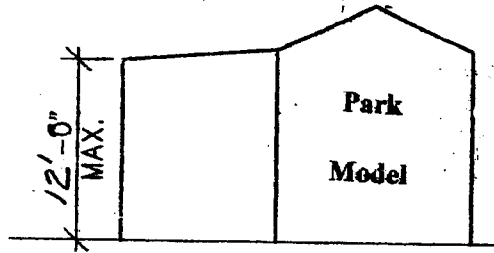
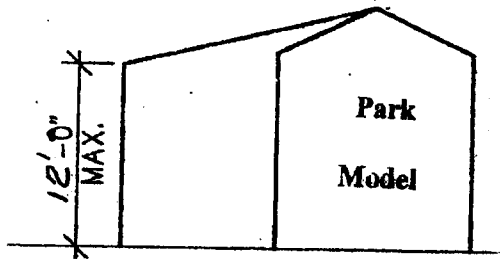

Illustration for Attached Awning, Arizona Room or Screen Room



Alternative Illustration for Arizona Room

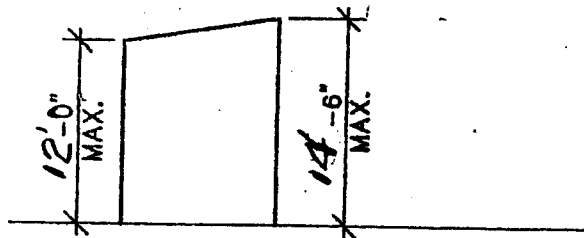
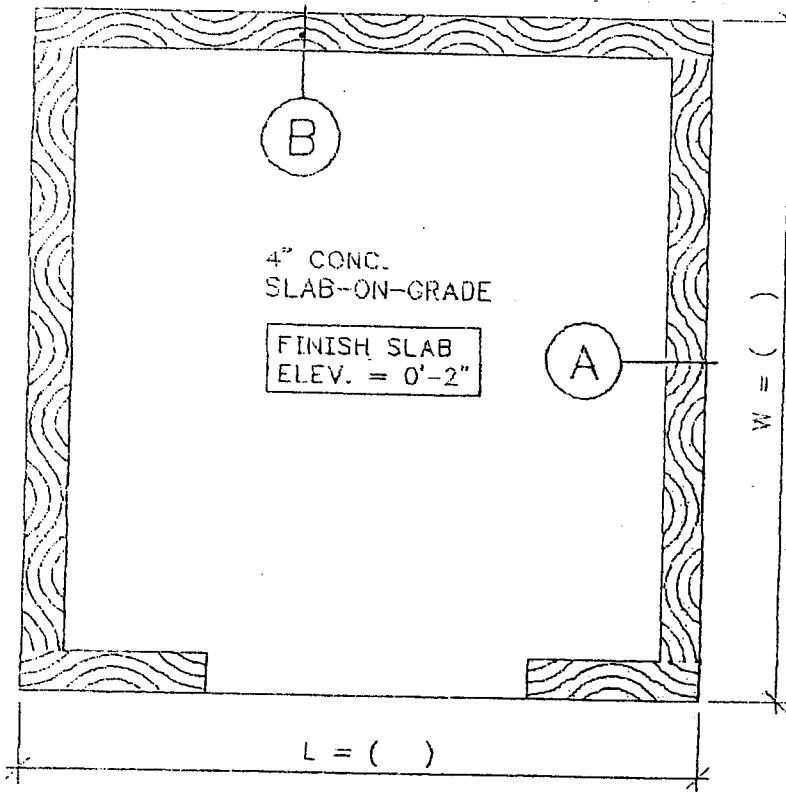

Illustration for Free Standing Awning, Arizona Room or Screen Room

TYPICAL ELEVATION
 FREE STANDING AWNING or ARIZONA ROOM
 ATTACHED: AWNING, SCREEN ROOM or ARIZONA ROOM
 NOT TO SCALE

EXHIBIT "E"



OWNER:

ADDRESS:

LEGAL LOT#:

LxW < 120 SQ. FT.

L OR W > 5 FT.

PLAN

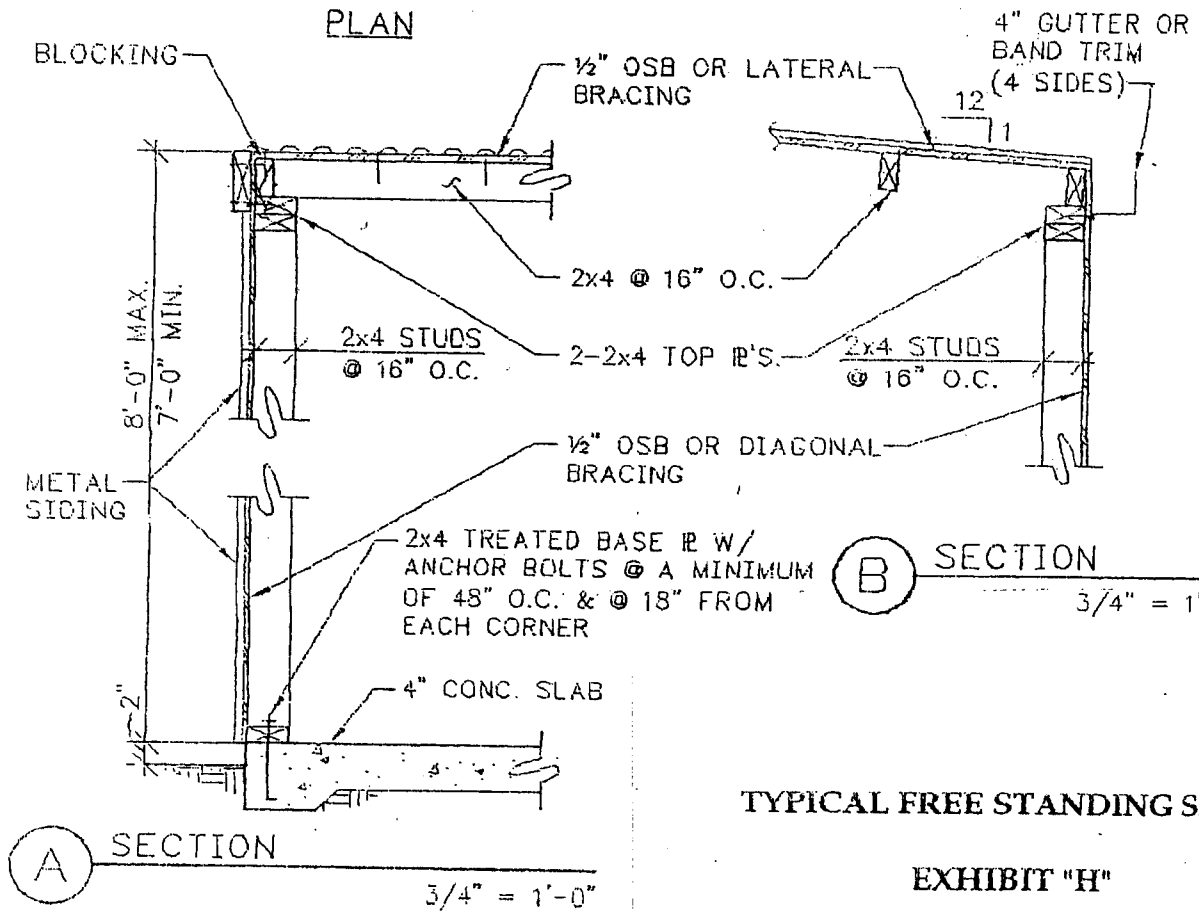

TYPICAL FREE STANDING S

EXHIBIT "H"

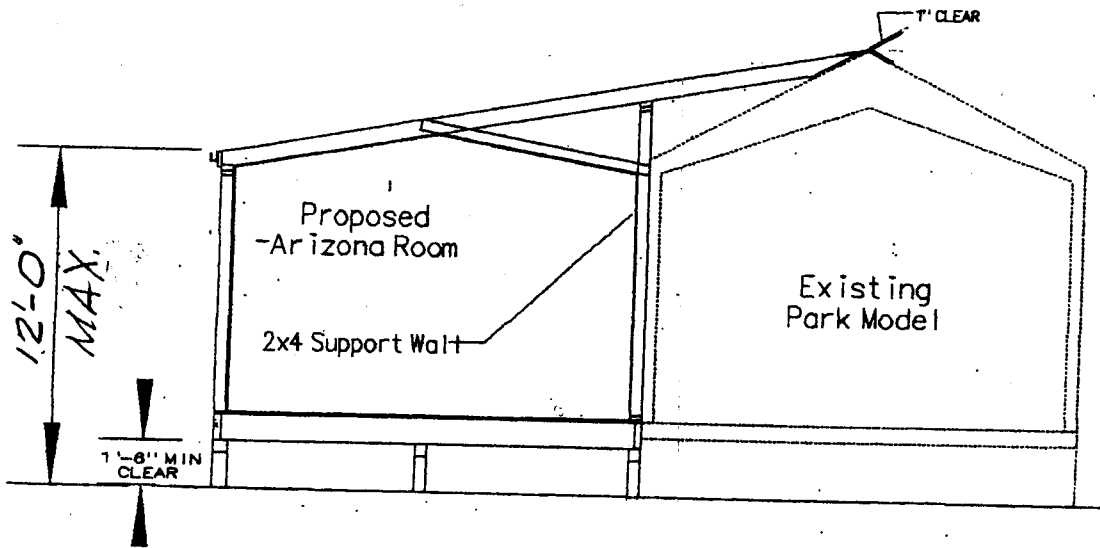
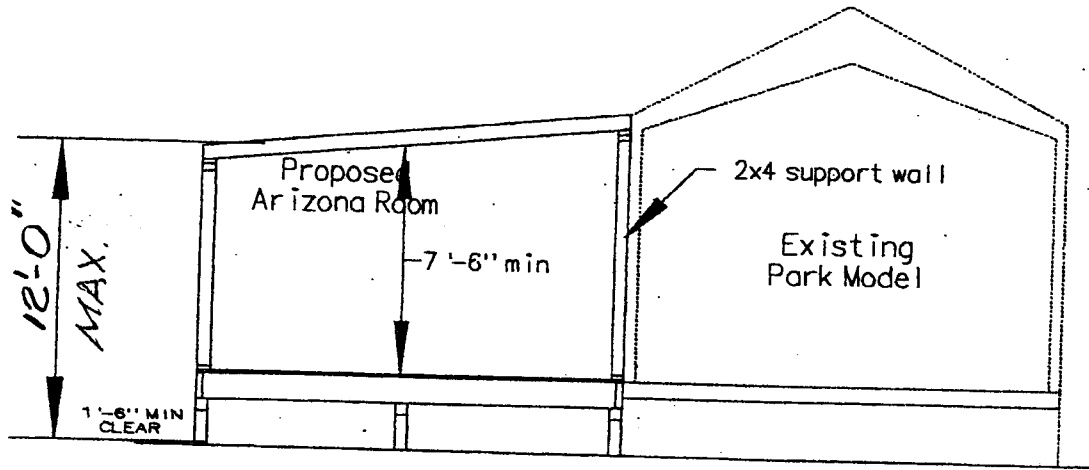

TYPICAL ROOF LINES

EXHIBIT "G"